

OKI



FOR MOST PRODUCTIVE PRECISION

Color Painter™ M-64s



COLORPAINTER M-64s THE PRECISE PROFESSIONAL

The SX ink logo features the letters 'SX' in a bold, blue, sans-serif font with a green swoosh underline. The word 'ink' is in a smaller, blue, sans-serif font to the right.

+

Color Painter M-64s

=

Eco Ink

Low odor
Outstanding outdoor durability
Wide colour gamut with high density

Fast

High speed print heads
High volume ink bags + subtanks
Short dry time

Precise

Superior image quality
Smart nozzle mapping
Active ionizer

Reliable

Nozzle guarded printhead
Reliable winding system
3 years warranty

Easy Operation

Automatic adjustments
Smart take-up unit
CP-Manager



or Painter M-64s



- Printed on Photo-Paper**
- Brilliant and bright presentation of photos
 - Huge colour gamut
 - Photorealistic printout
 - Printed on M-64s

23 REVOLUTIONIZING REASONS FOR OUTSTANDING INKJET PERFORMANCE

1 Low odor eco solvent SX ink

2 Wide color gamut

3 Outstanding outdoor durability

4 High Density

5 CMYK Lc Lm + additional Grey

1 High Speed Print Heads

2 Built-in Sub Tanks

1 Smart Pass Technology 4 (SP4)

2 Dynamic Dot Printing Technology

3 High volume ink bags

4 Optimized Air Flow System & Large Heater

3 Smart Nozzle Mapping 3 (SNM 3)

4 Active ionizer

5 Premium manufactured printer





1 Nozzle guarded print heads

2 Reliable winding system

3 Stable Media Advance

4 Automatic washing machine for print heads

5 3 Year Warranty

1 Automatic print adjustment

2 Slide out mechanism at take-up unit

3 CP-Manager

4 Easy access for fast technical service

AT A GLANCE

SPECIFICATION

Model	IP-6620-00 ColorPainter M-64s
Print Head	Industrial High-Frequency drop-on-demand piezo print head
Number of Nozzles	508 nozzles/head
Maximum Resolution	900 x 900 dpi
Visual resolution	photorealistic printout
Maximum Media Width	1.626mm (64")
Maximum Print Width	1.616 mm (63,6")
Printing Speed	3.5 to 66,5 m ² (38 to 716 sfph)
Media Weight	Up to 50 kg (110 lbs)
Maximum Media Diameter	220 mm (8,7")
Margin Size	5 mm (1/5") on each edge (with rolled media, without edge guards)
Ink Type	Eco-Solvent SX ink with Greengard certification
Color	6 (CMYK,Lc, Lm) or 7 (CMYK, Lc, Lm, Gy)
Maximum ink capacity	1,5 Liter per color
Media	Vinyl, banner, paper, blueback, backlit, canvas, technical textiles
Heater	3-way built-in heaters (Pre, Print, After)
Take-up Modes	tension or loosen inside or outside winding
Interface	USB 2.0
Power Source	200 bis 240 VAC, 12a, 50hz/60hz
Power Consumption	Start-up 2,880 W or less, stand-by 100W or less
Operating Environment	15 – 30 °c (59 – 86 °f), 30 – 70 % rh (no condensation)
Storage Environment	5 – 35 °c (41 – 95 °f), 10 – 80 % rh (no condensation)
External Dimensions	3.095 (W) x 935 (D) x 1.247 (H) mm, (122" x 37" x 49")
Weight	321 kg (708 lbs.) or less without media and ink
Software	Onyx Rip Center Special Edition included

OPTIONS

Cutter unit	With practical fixations for a perfect cross cut after printing
Exhaust Attachment	allows the installation of an exhaust system
2" Flange	Media for rolls with a core diameter of 2 inches

Eco Ink

REVOLUTIONIZING LOW-ODOR ECO SOLVENT INKJET PRINTER

High-speed print engine plus Eco SX ink achieve unmatched performance for indoor and outdoor applications.

1 Low odor eco solvent SX ink

The ink covers the full range of long-life outdoor signage and high-quality indoor graphics. In addition to low running costs the low odor ink does not smell on the final application. SX ink has an approval from the Nordic Ecolabel and a Greenguard Gold certification.

2 Wide colour gamut

With its wide colour gamut, it is possible to print the widest range of standard RAL or Pantone colours, especially in the important Red and Blue tones.



3MTM MCSTM Warranty

3 Outstanding outdoor durability*

SX ink by OKI has the same familiar high-class performance as its mild solvent GX ink. SX ink offers high-speed printing and outstanding image quality at the same time through precise drop control, high scratch resistance, good chemical durability etc. It offers UV stability of 3 years+ without lamination. It is also approved in the 3M MCS Warranty Program and the Avery ICS Warranty Program which offer much longer extended outdoor warranties.

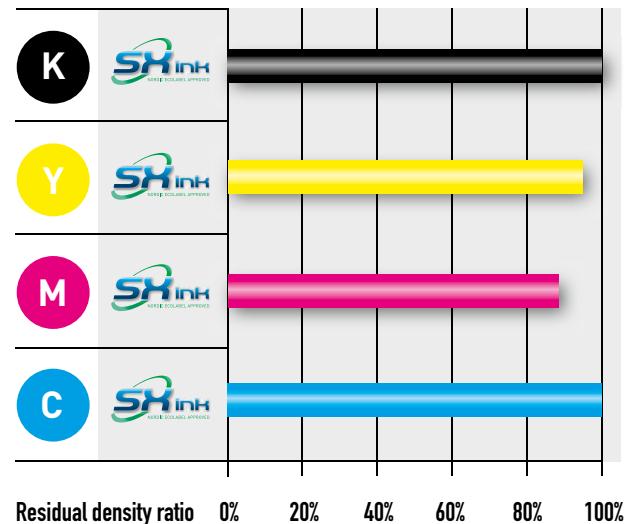

36 months later

* Based on the results of accelerated weather test by OKI. OKI does not guarantee outdoor durability.

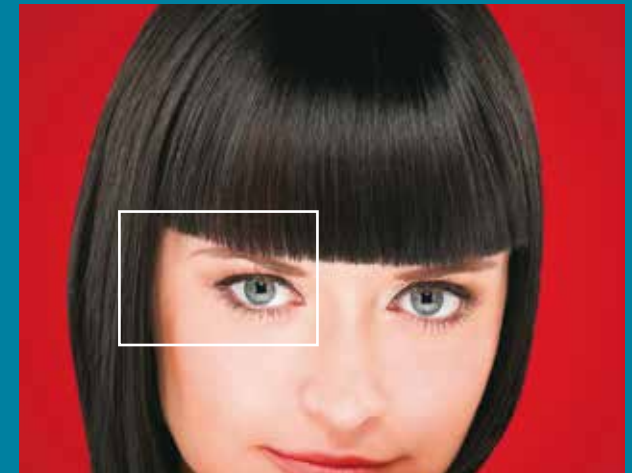

4 High Density

The SX ink achieves high-density colours and details in dark areas. It meets the customer's demand for sharp, clear and bright signs especially for backlit applications.

5 CMYK Lc Lm + additional Grey

The 7-color model offers grey ink in addition to the standard 6-color configuration. The additional Grey enlarges the color space and refines the soft gradients and shades, especially in skin tones and

soft colors. Another advantage is the creation of a real greyscale monochrome image, only printed with Black and Grey in comparison to a CMYK greyscale picture this reduces ink costs drastically.

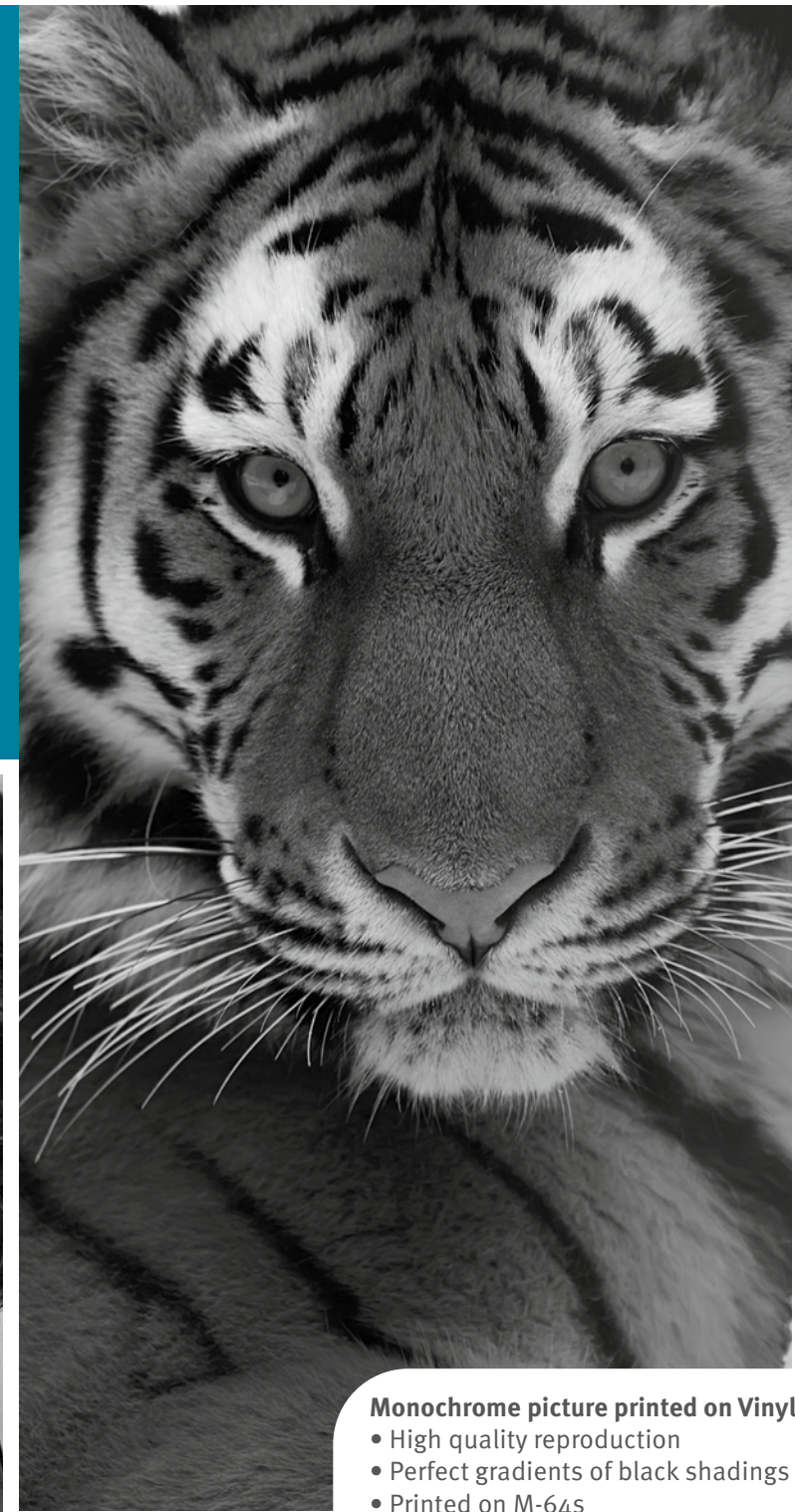

Monochrome picture printed on Vinyl

- High quality reproduction
- Perfect gradients of black shadings
- Printed on M-64s

Fast

SMART AND INDUSTRIAL FEATURES FOR PRODUCTION ENVIRONMENTS

ColorPainter M-64s provides unmatched productivity and quality while reducing impact on the environment.

1 High Speed Print Heads

Industrial high-frequency greyscale print heads realize a maximum print speed of 66.5 m²/h. Even production in High Speed Mode does not lose density. For special applications it is possible to increase density without reducing print speed.

2 Built-in Sub Tanks

One built-in sub tank per colour assures continuous printing without interruption of running print jobs while exchanging ink bags. Ink bags will be emptied completely. As ink is delivered in space-saving ink bags for reloadable cartridges we reduce landfill waste.

3 High volume ink bags

1.5 liter ink bags support continuous high-volume printing. The printer is equipped with cartridge holders for 1.5 liter ink bags. Only the bags have to be exchanged. This minimizes the waste volume of empty ink bags.



Banner	High Speed	66.5 smph (716 sfph)
	Fast Produktion	49.7 smph (535 sfph)
	Produktion	33.1 smph (356 sfph)
	Standard	23.9 smph (257 sfph)
	Quality	16 smph (172 sfph)
	High Quality	9.2 smph (99 sfph)
PVC	High Quality	9.2 smph (99 sfph)
	Max Quality	6 smph (70 sfph)

Print speed of printing on 64" wide media

4 Optimized active air flow system+ large Heater

The air flow inside the printer has been redesigned for faster ink drying. The active air flow system brings air from the rear of the printer and blows along the front cover out of the printer. This air flow coupled with a large heater makes it possible to dry our low odor eco SX ink quickly.

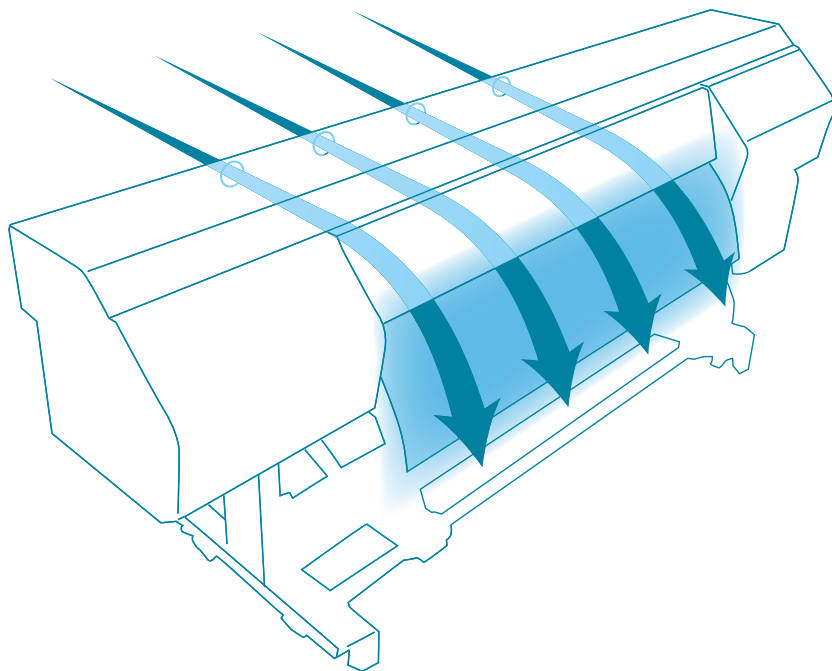

- Art reproduction printed on canvas**
- Motives gain extremely depth
 - Outstanding colour intensity
 - Brilliant, saturated colour coverage
 - Printed on M-64s

Precise

HIGH PRECISION TECHNOLOGY TO MAXIMIZE PRINT QUALITY

Innovative and unique technologies implemented in firmware and hardware



1 Smart Pass Technology 4 (SP4)

The special dot control algorithm of SP4 controls ink amount to generate the ideal ink drop size to result in a superior image quality. This makes the printer perfect for both, high-quality indoor and long-life outdoor applications and effectively eliminates banding without any loss in quality and speed.



2 Dynamic Dot Printing Technology

DDP controls and optimizes dot size and dot density to make consistently rich bold glossy colours with fine details. It also facilitates high density printing without detail and speed loss. This is ideal for backlighting applications.



3 Smart Nozzle Mapping 3 (SNM 3)

A new dot control algorithm has up-graded the performance of the Smart Nozzle Mapping function, compensating missing dots precisely when nozzle clogging occurs. It compensates up to 10 nozzles per print head without restricting the print quality or speed.

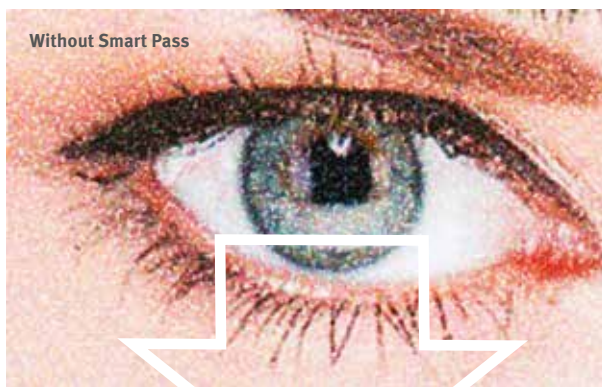

Without Smart Pass

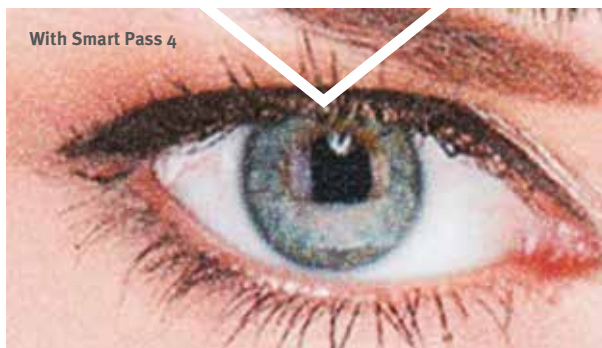

With Smart Pass 4

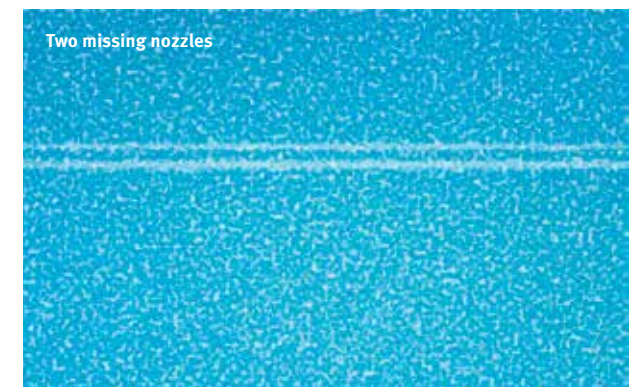
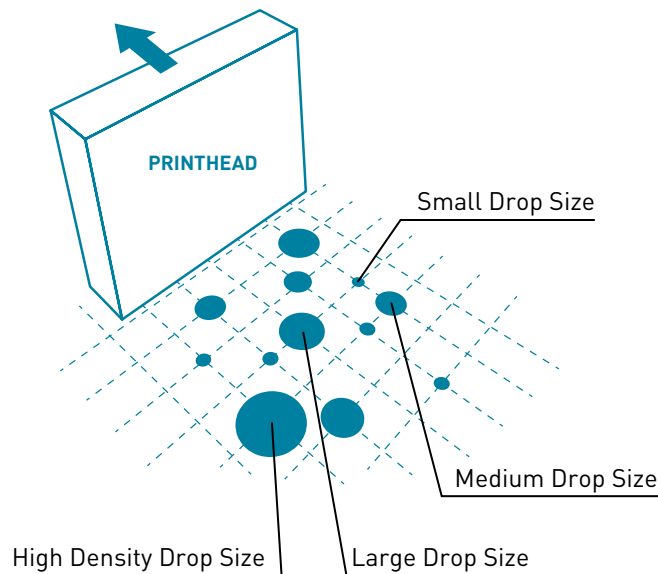

Two missing nozzles



Two mapped nozzles with SNM2

4 Ionizer

Static electricity can cause print defects on special indoor media which are electric static sensitive. The active on-carriage ionizer neutralizes static electricity on the media, reducing static-related print issues – even in low humidity environments. It helps to keep printing consistent during the complete year.

5 Premium manufactured printer

OKI printers stand for sturdy, reliable and precise construction, made for production environments and high quality awareness.



Window graphic (backlit)

- Excellent colour density
- With intensive Deep Black
- Which blocks the light

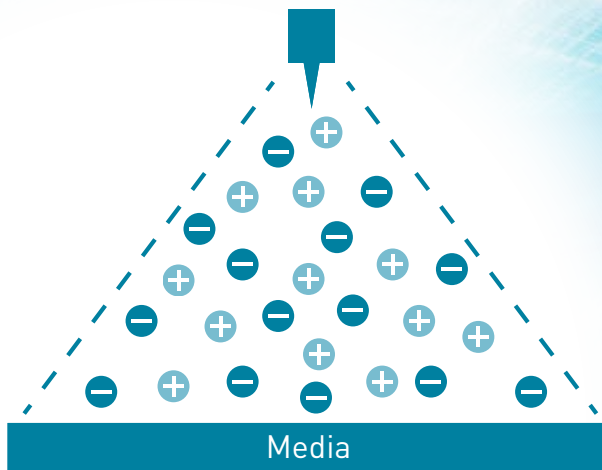

Reliable

INDUSTRIAL AND WELL DESIGNED CONSTRUCTION

Highly advanced engineering skills for mechanical, electronical and firmware development ensure extraordinary reliability.

1 Nozzle guarded print heads

508 Nozzles per head are protected against mechanical damages through difficult, stiff or heat-sensitive media by an additional guard underneath the print head.



2 Reliable winding system

The winding system with the take-up unit offers a tension mode and a loose mode to reduce stress on the print surface and supports reliable unattended printing. Tool to handle heavy rolls included.



3 Stable Media Advance

The stable media feeding and precise winding of the take-up unit allow easy further processing and finishing of the printed media.



4 “Automatic washing system” for print heads

A “print head washing system” automatically moistens the head’s surface with a sponge first and cleans it properly with two wipers afterwards.



5 Warranty

We provide a warranty of 3 years on hardware and print heads, without any nozzle shot restriction. Ready for production.

Fast - Precise - Reliable = Ready for production!

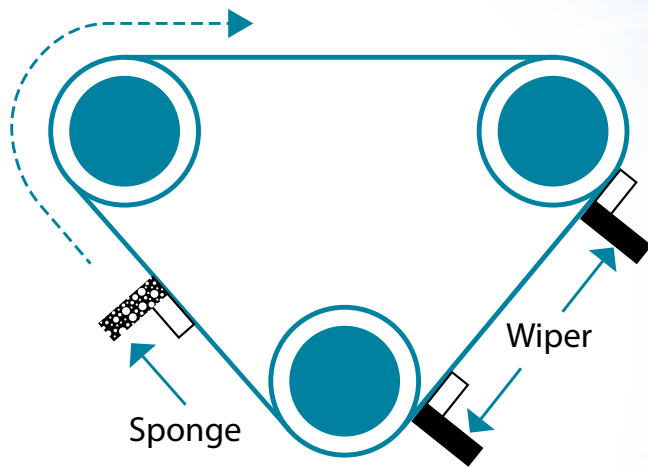

Label & Stickers

- Excellent colour density
- With intensive deep Black
- Printed on M-64s

Easy
Operation

EASY TO OPERATE BY USER-FRIENDLY FEATURES



1 Automatic print adjustment

The printer has optical sensors that automatically perform both media advance and bi-directional position adjustment. The operator does not have to make complicated manual adjustment when a new media has been installed or when the print mode has been changed. This automatic print adjustment ensures high quality printing even for first time users.

2 Slide out mechanism at take-up unit

The take-up unit of the M-64s has a slide-out mechanism allowing users to load and unload media easily.

3 CP-Manager

Developed specifically for the ColorPainter printers. CP-Manager, the bundled controller software, provides the operator printing status, error or warning messages and offers an easy access to printer-settings and printer-parameter. Everything very easy via PC, mobile device or twitter.

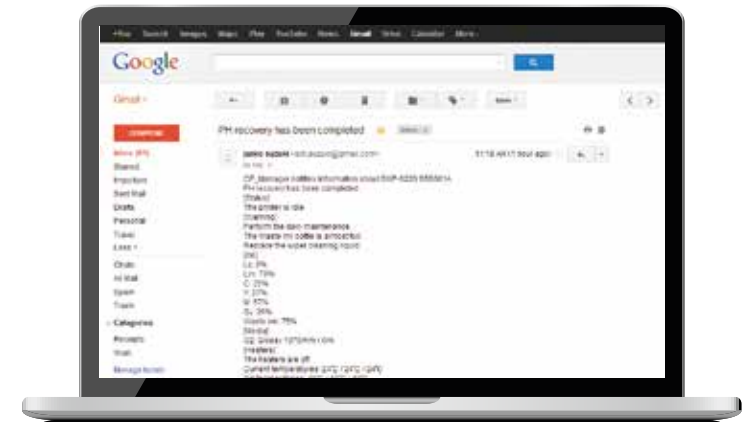

Color On Time

Fast. Precise. Reliable.

Focusing on **"Time"**, OKI Data Infotech Corporation has been dedicated to pursuing the ideal for wide format printers for sign and graphics professionals. **"Color On Time"** represents our credo for **"Manufacturing"** with **"Fast"**, **"Precise"** and **"Reliable"** as the three key elements. We strive to develop and manufacture products and services that benefit customers' **"Time"**.

Backlit Samples – printed on M-64s

- With details in dark shaded areas and smooth gradients in skin tones



OKI

© Copyright 2017 OKI EUROPE LTD. OKI EUROPE (Benelux) is the trading name for OKI EUROPE LIMITED having its registered office at Medialaan 24, B-1800 Vilvoorde, Belgium, a branch office of OKI EUROPE LIMITED, a company registered in England under company number 02203086, its registered office being Blays House, Wick Road, Egham, Surrey, TW20 0HJ, UK. OKI EUROPE LTD is part of the Oki Electric group of companies.
Specifications subject to change without notice. All trademarks acknowledged. Version Number 01/2018.



OKI EUROPE (BENELUX)

Medialaan 24,
B-1800 Vilvoorde,
Belgium
Tel +32 (0)2 257 4620
www.oki.com/be